



# TECHNICAL SHEET



# 150

Cod.: MP.0.165 US  
Rev.: 2



**Next Hydraulics®**  
RAISE YOUR EXPECTATIONS



DIMENSIONS		
CRANE	A	B
ML 150.1	53 3/4"	27"
ML 150.2	53 3/4"	27"
ML 150.3	53 3/4"	31"

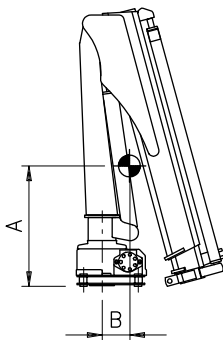
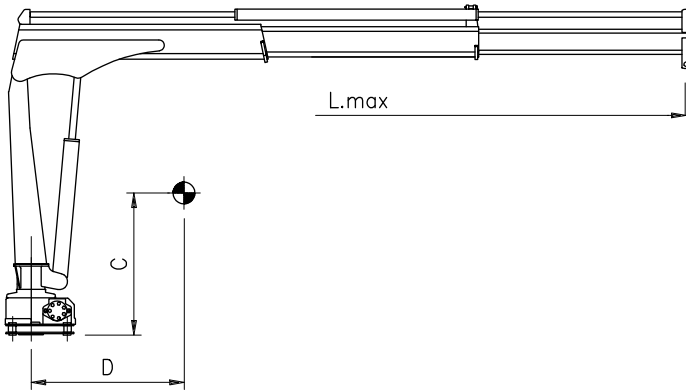
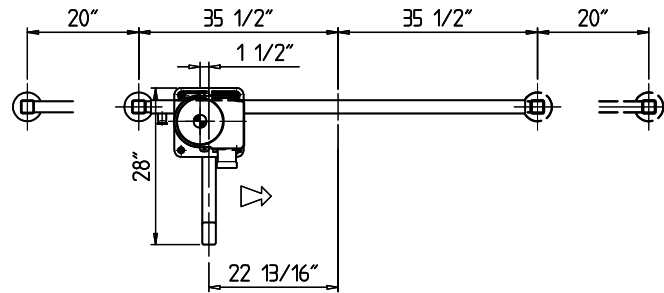
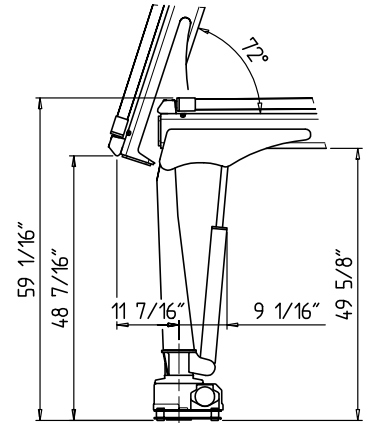
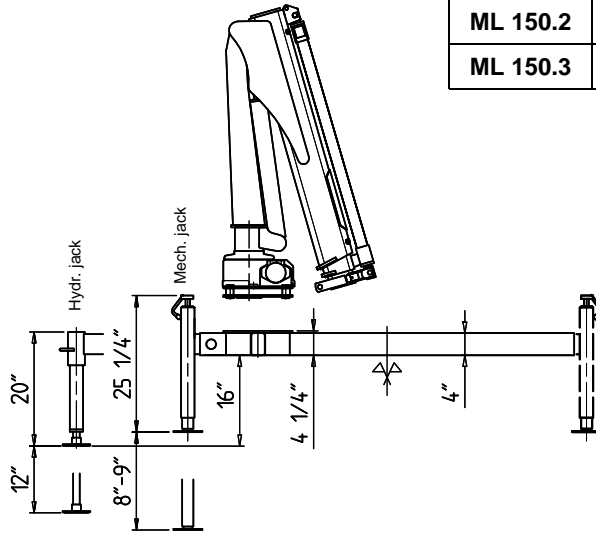
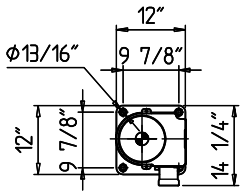
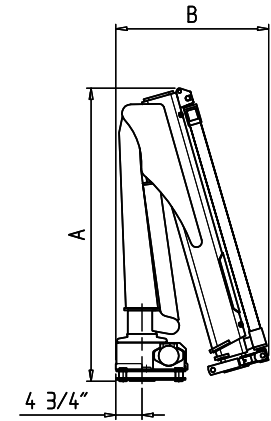

CRANE	A	B	C	D	L max
ML 150.1	20"	4 3/4"	30 1/4"	19 3/4"	118"
ML 150.2	20 1/2"	5 1/2"	32 3/4"	24"	118"
ML 150.3	20 7/8"	6 3/4"	34 5/8"	33"	157"

Standard control station

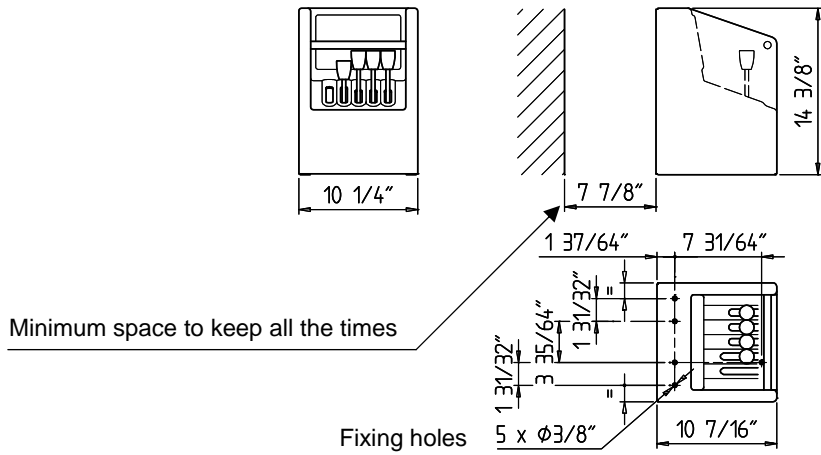

Control station with remote control

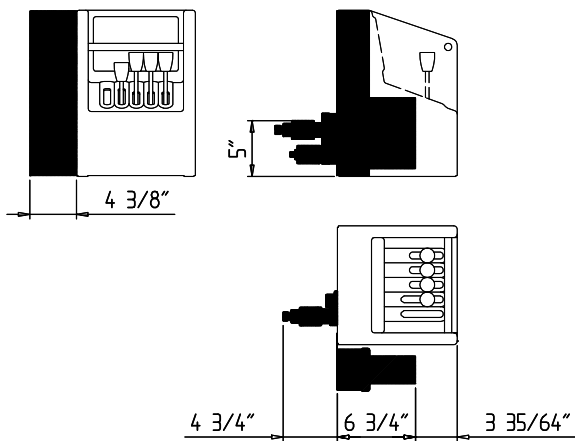

Oil tank for H version

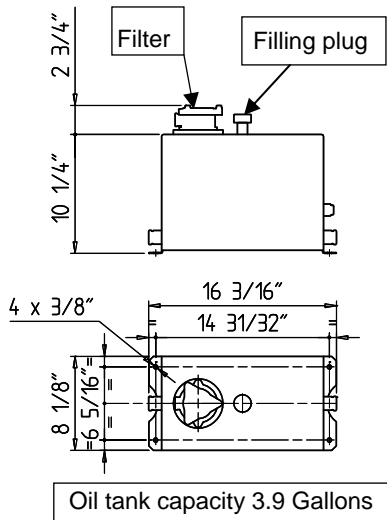

Power pack (E version)

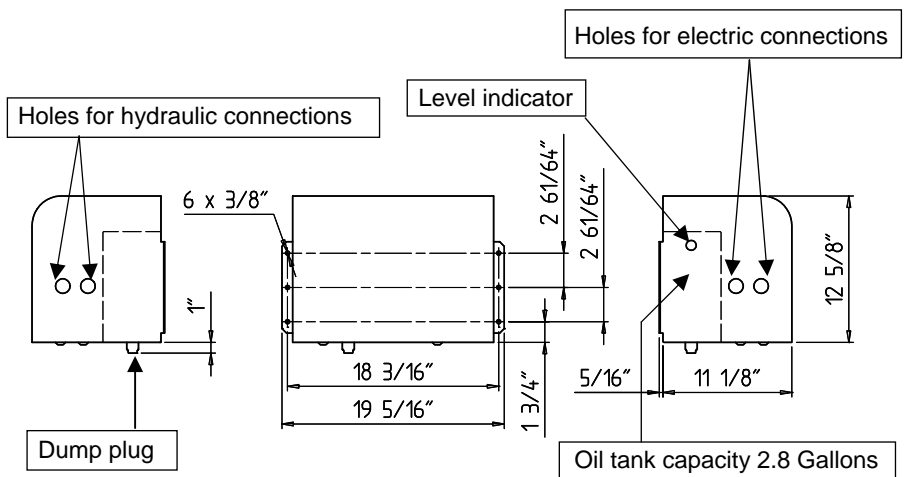

TECHNICAL DATA	U.M.	VERSION			
		ML 150.1	ML 150.2	ML 150.3	
CRANE RATING	ft lbs	10350			
STANDARD EXTENSIONS Nr (HYDRAULICS)	N°	1H+1M	2H	3H	
STANDARD OUTREACH	ft	9' 11"	9' 11"	13' 1"	
SLEWING ANGLE	°	330°			
MAXIMUM ANGLE SLOPE	°	5°			
SLEWING TORQUE	ft lbs	1180			
MAX. LIFTING HEIGHT FROM CRANE BASE	ft	13' 1"	13' 1"	16' 5"	
SUGGESTED OIL FLOW	gpm	1.6÷2.1			
MAX. WORKING PRESSURE	p.s.i.	3045			
BASIC CRANE WEIGHT	lbs	VERS. "H"	365	385	410
		VERS. "E"	410	430	450
BASE WEIGHT WITH EXTENDABLE STABILIZERS	lbs	140÷195			
BEAM WEIGHT WITH 2 EXTENDABLE STABILIZERS	lbs	130÷135			
MOTOR ABSORPTION FOR ELECTROHYDR. CRANE 12V	A min/max	70/170	70/170	70/170	
MOTOR ABSORPTION FOR ELECTROHYDR. CRANE 24V	A min/max	35/85	35/85	35/85	

WINCH SPECIFICATIONS	U.M.	
MAX. WINCH SINGLE LINE CAPACITY (3 <sup>rd</sup> LAYER)	lbs	1100
ROPE DIAMETER	inches	1/4"
ROPE LENGTH	ft	82
WINCH KIT WEIGHT	lbs	110

VERSION	DESCRIPTION
"E" 12V	ELECTROHYDRAULIC
"E" 24V	ELECTROHYDRAULIC
"H"	HYDRAULIC

OPERATING TIMES										
VERS.	SLEWING (rpm)	LIFTING (sec)		LOWERING (sec)	EXTENSION OUT (sec)			EXTENSION IN (sec)		
		p min	p max		150.1	150.2	150.3	150.1	150.2	150.3
"E" 12/24V	1.8	14	27	15	12	25	33	6	12	17
"H" (PTO)	2.0	14		15	12	25	33	6	12	17

p min: min. working pressure  
p max: max. working pressure

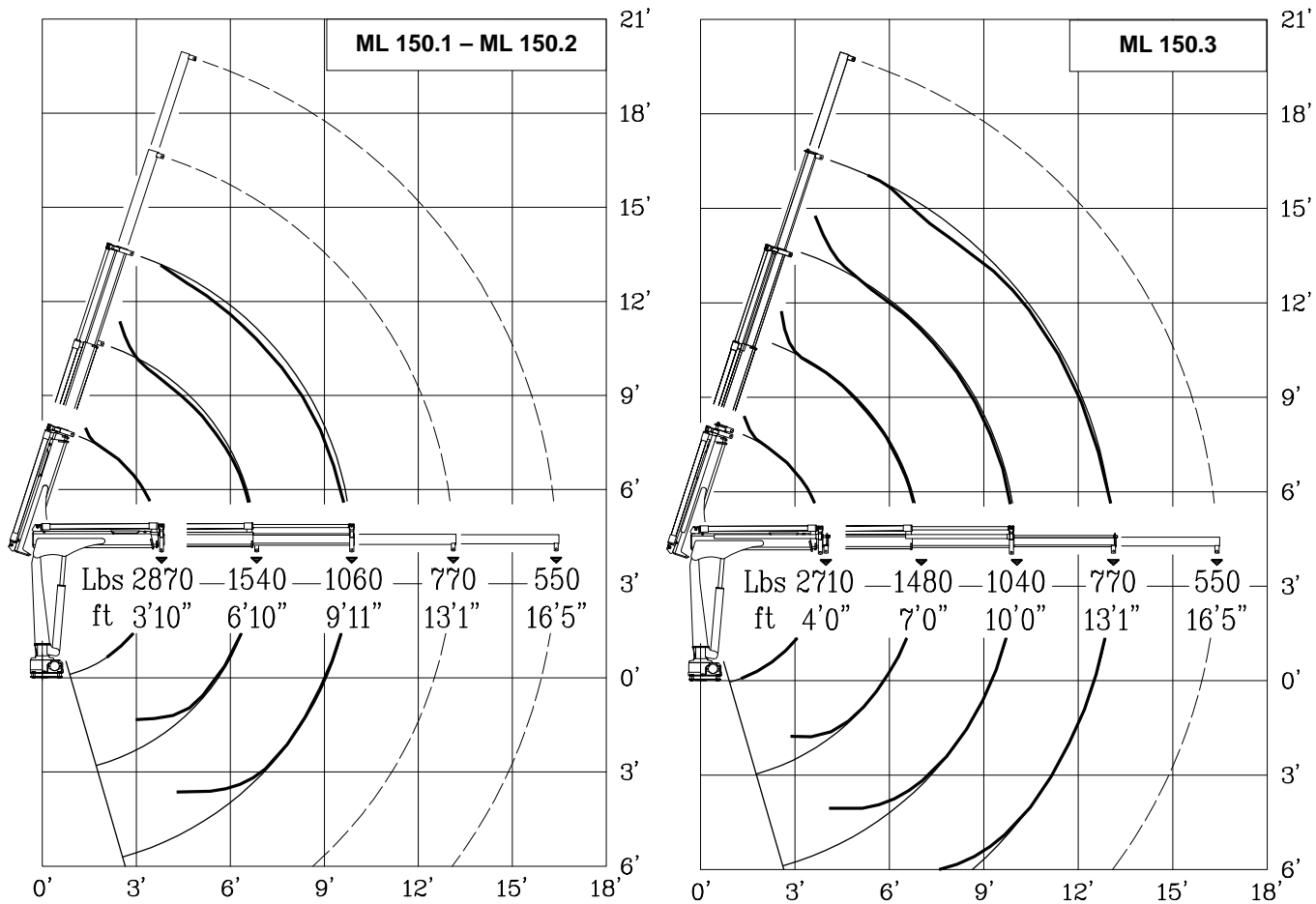

Lifting class **HC1 – HD4/B2**



